

## A50R

<b>BRAND NAME</b>	Resilmount A50R™
<b>DESCRIPTION</b>	Resilient Isolation Hanger
<b>MANUFACTURER</b>	Studco Building Systems
<b>DATE OF ISSUE</b>	March 2009

### ➤ Trademark



### ➤ Image

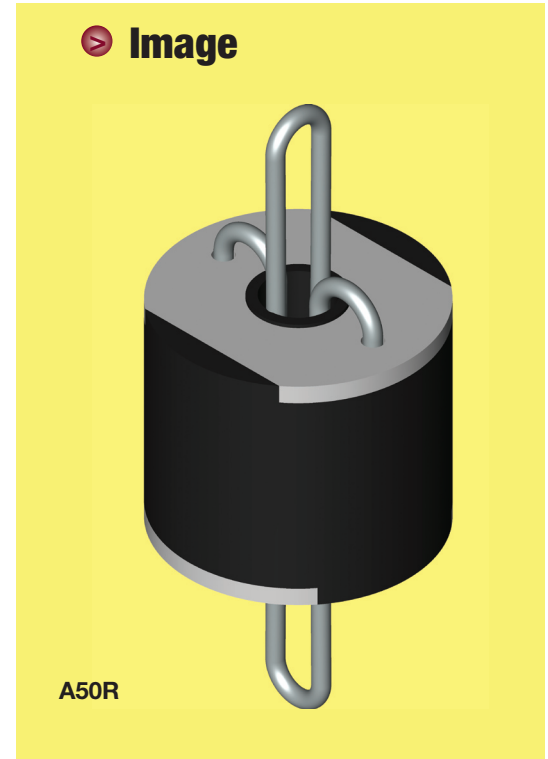

### ➤ Application

Resilmount™ A50R is specifically designed for the support and acoustical isolation of internal suspended ceiling systems.

### ➤ Features

- ✓ Suits standard 3/16" hanging rod
- ✓ Easy installation into new or existing ceiling systems
- ✓ Meets Australian Standards and ABCB guidelines
- ✓ Does not reduce the load capacity of the ceiling system
- ✓ Suitably isolates the ceiling system from the structure to reduce structure-borne noise
- ✓ Elastomer Type: Natural Rubber
- ✓ Shore A Hardness: 65
- ✓ Load capacity: 110 lbs.

### ➤ Dynamic Characteristics

Rubber mounts differ from spring mounts is that the natural frequency is a function not only of the deflection but also of the rubber hardness.

The noise absorption properties of the Resilmount™ A50R allow it to deflect 3/16" when loaded to 110 lbs., in accordance with Australian Standards, which provided optimal isolation of transferred noise.

### ➤ Installation Notes

When selecting hangers, it is recommended that the calculated mass of the ceiling system is increased by 10-20% to avoid overloading of the isolation element. If maximum rated deflections are required, the ceiling system needs to be accurately weighed and point loads assessed in accordance with the architectural specifications of the project.

The site contractor can undertake normal installation procedures of the suspended ceiling system. Once the hanging rod has been hung from the substrate, the lower end of the rod needs to be bent up in accordance with the ceiling system manufacturers specifications, providing a hook on which the Resilmount™ A50R can be hung.

Once the mount is in place, another section of hanging rod is required to be bent and inserted through the lower side of the Resilmount™ A50R. The shaft of this rod then becomes the mounting point for the ceiling suspension clip.

### ➤ Dimensions

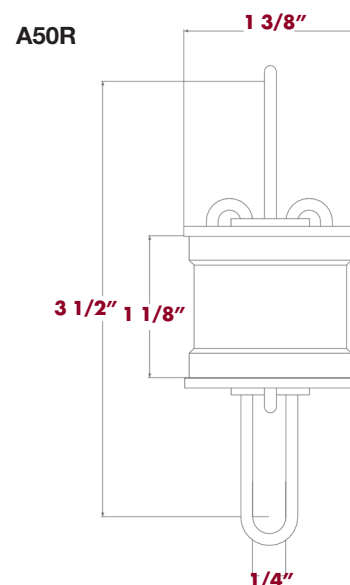

**For Technical Support & Assistance, Please Contact Studco Technical Services 800.675.8023**