

A24R

BRAND NAME	Resilmount A24R™
DESCRIPTION	Resilient Joiner Bracket
MANUFACTURER	Studco Building Systems
DATE OF ISSUE	March 2009

➤ Trademark



➤ Image

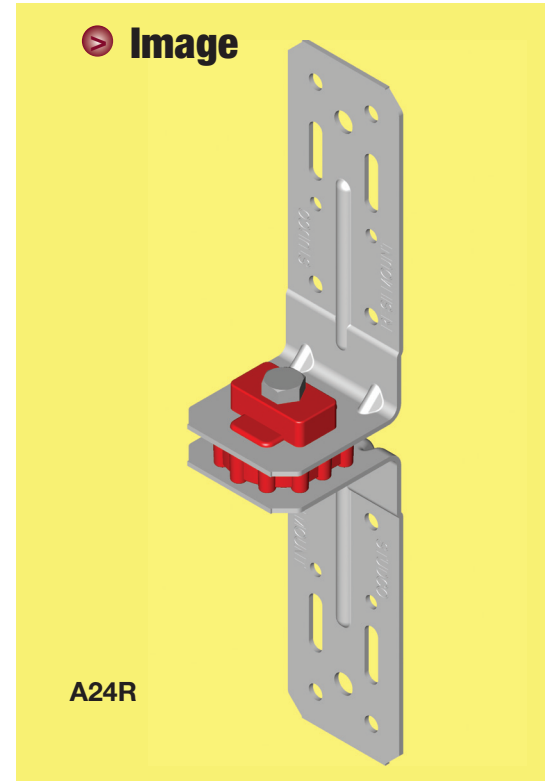

➤ Application

Resilmount A24R™ is an engineered, acoustic resilient mounting bracket for reducing airborne vibration and structure-borne vibration in an internal chase wall application where acoustical bridging is required. Using the Resilmount A24R bracket improves the strength and rigidity of chase walls, allowing both walls to support each other whilst remaining completely acoustically isolated.

➤ Features

- ✓ Fully engineered component, designed to improve wall strength and increase wall height, without compromising any acoustical properties of a chase wall installed in an acoustically sensitive environment.
- ✓ Uses Resilmount's new heavy-duty bracket which is specially designed to help absorb vibration and minimize structure-borne noise
- ✓ Incorporates Resilmount's amazing new thermoplastic rubber mount
- ✓ Wall heights can be increased in acoustic chase wall applications, eliminating the need for extensive bracing and oversize steel members.
- ✓ Simple design makes it adaptable to hundreds of applications
- ✓ Does not use metal washer or metal insert in rubber
- ✓ Provided with several fastening holes including 3/16" slotted holes in bracket fixing surface.
- ✓ Supplied as fully assembled component – no site assembly required.
- ✓ Consistent and reliable quality – manufactured under ISO9001 quality control system
- ✓ Resilmount is the most cost effective way to isolate airborne noise

➤ Dynamic Characteristics

Resilmount's patented thermoplastic rubber outperforms standard rubber because of its unique natural absorbing characteristics. Resilmount's unique sound cell design guards against structure-borne vibrations transferring into the body of the Resilmount because of its strong column design that allows only minimal contact surface area with the structure or substrate to which it is fastened. This aids in absorbing and breaking up airborne sound at its transfer point.

➤ Installation Notes

- Minimum gap between walls is 2". Smaller gaps down to 1" can be achieved by fixing the bracket on a diagonal plane between the two walls. When mounting the bracket diagonally, extreme care must be taken to ensure the bracket's fastening surface does not come into contact with the studs on the opposing wall.
- Maximum gap between walls is 7". Greater distances can be achieved by extending the bracket length using a piece of stud. In such instances, please contact Resilmount's engineers to confirm engineering specifications.
- A24R to be fastened to structure with a minimum #8 screw or masonry sleeve anchors (see fasteners manufacturers specifications).
- When installing, ensure that no part of the two opposing structures are touching or has the potential to compromise the acoustical isolation of the two separate structures.
- Load ratings to be confirmed with Resilmount engineers, based on project environment.

➤ Dimensions

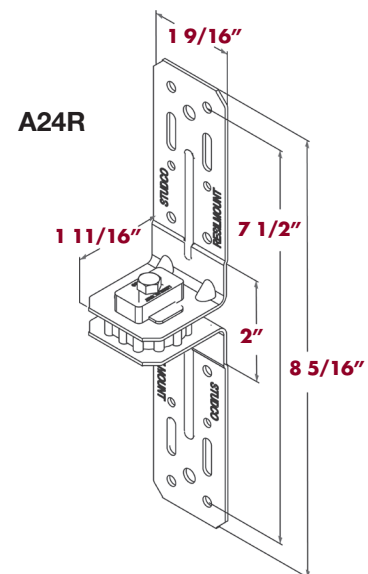

For Technical Support & Assistance, Please Contact Studco Technical Services 800.675.8023